

EXPLODED VIEW

#630101 FX T300 TUNED

No. Engine	
631103.3-252705	

INCLUDED ENGINE HEAD SHIM	
635900	0.10mm
635901	0.15mm
635902	0.20mm

INCLUDED SHIM UNDER SLEEVE	
633900	0.10mm
	0.15mm
	0.20mm
WITHOUT	0.00mm

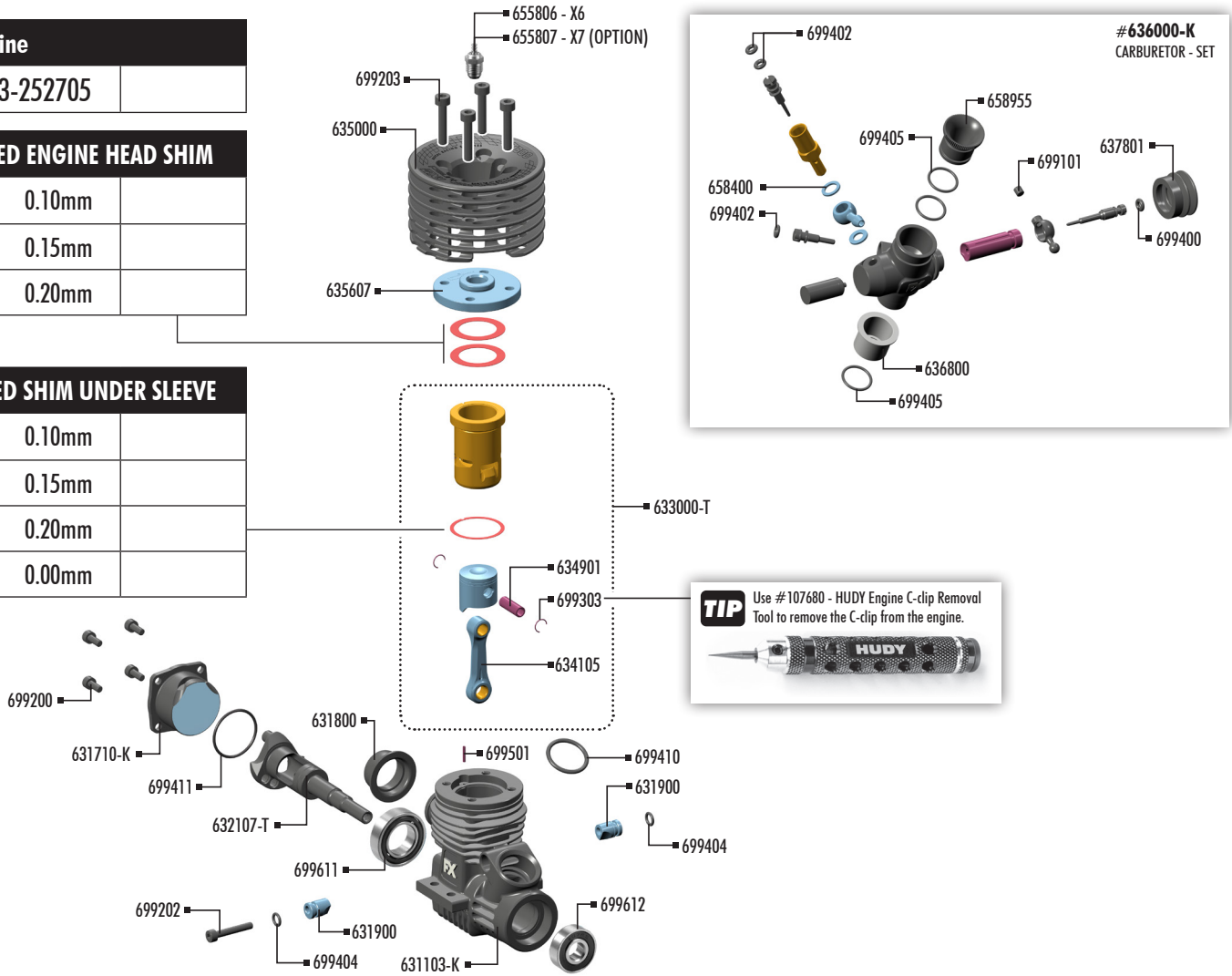

CARBURETOR SETTINGS

Factory carburetor setting for break-in procedure

The carburetor comes preset from factory and you have to start the break-in procedure with the following setting:

1 Main High-speed Needle (Upper)	0mm inside the needle body
2 Low-end Needle (Front)	0mm inside the needle body
3 Idle Adjustment Screw	Size measured with carburetor boot compressed approx 42mm

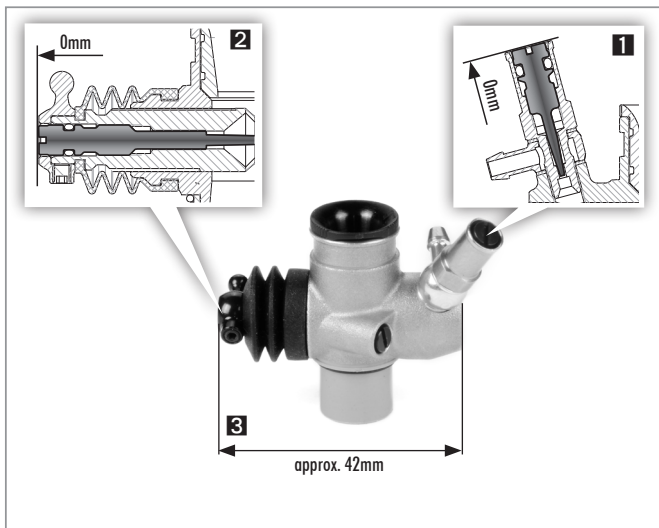

Basic Carburetor Setting after break-in procedure

After you have finished the break-in procedure this is the basic carburetor setting. Any time you get lost return back to this basic setting.

1 Main High-speed Needle (Upper)	approx. 0mm inside the needle body
2 Low-end Needle (Front)	approx. 0~0.3mm inside the needle body
3 Idle Adjustment Screw	Size measured with carburetor boot compressed 40.8mm

